

## DESCRIPTION

Mechanical system to synchronize two 3-way valves with a single handle.  
Designed to move two three-way valves simultaneously with a single handle (by-pass - closed - sample).  
Through this system it is possible to move two three-way valves with a single handle at the same time.  
The change of position assures to through zero closed position.  
Can be manufactured with valves from the main brands on the market (under requirement).

POSITION 1



CLOSED POSITION

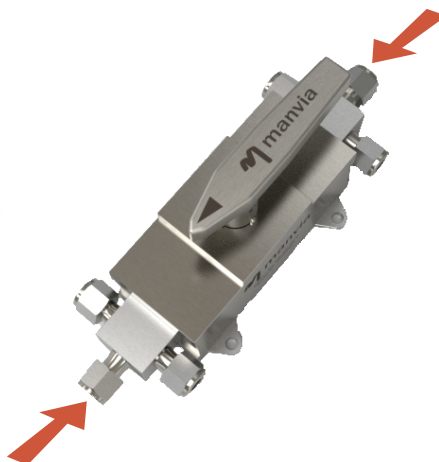

POSITION 2

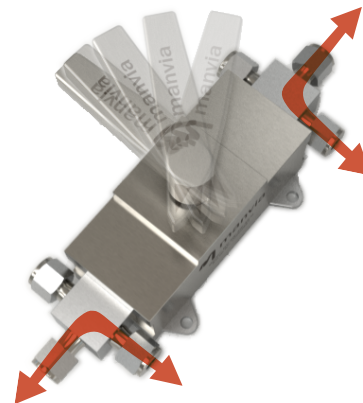

### SPECIFICATIONS

Materials:	SS316L
Max. Temperature:	230°C (446°F)
Max. Pressure:	207 barg@ (3000psig).
Valves connections:	1/4"OD
Size:	Two or Three-way
Weight:	1,4Kg (3,01lb)

### ORDERING INFORMATION

<b>BLOCK SELECTOR</b>	<b>BS</b>	-	<input type="checkbox"/>	-	<input type="checkbox"/>	-	<input type="checkbox"/>	-	<input type="checkbox"/>
Valve 1									
3W	Three way valve								
2W	Two way valve								
Valve 2									
3W	Three way valve								
2W	With Cooling or heating jacket								
Dead Man System									
-	Not included								
D -	Included								
Other Options									
-	On request								

### DRAWINGS

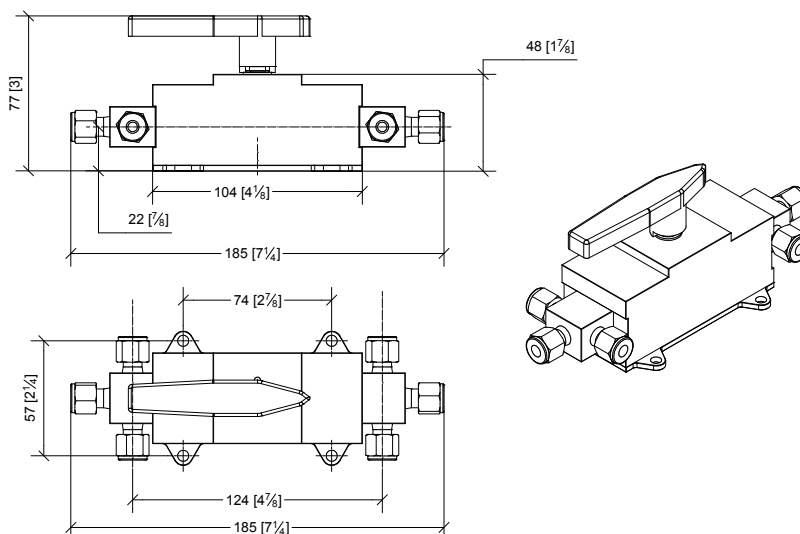

Units: mm [Inches in brackets]

Due to continuous improvements, Manvia reserves the right to change the design and specifications without notice